

Opus 200/135 Sensor

All our sensor fixtures have a white glazed ceramic bases and a movement sensor that is adapted for both indoor and outdoor use.

EAN / GTIN	7312908262569
E-number	7500365
Article no.	8262-506-10
Type designation	8263



Specification

Material	Porcelain
Base colour	White (NCS S 1000-N)
Glass	Matt opal glass
Glass thread (mm)	185,5 mm
Glass gasket	Silicone
Weight	2,2 kg
Diameter (mm)	202
Height (mm)	131
Lamp holder	E27
Light source	Max 20W (not included)
Effect	Max 20W
Rated voltage	230V
IP class	IP44
Insulation class	I
D class	No
IK class	IK02
Ta	-30 - +25
Installation	Ceiling/wall
CC measurement (mm)	133, 70
Knock out opening	3
Cable inlet	Bottom inlet
Cable glands	Bottom inlet
Cable area, max	Max 5 x 2,5 mm ²
Bridging	Yes
Surface mounted cable	Yes
Connection	Terminal block
Family	Opus
Design	Duoform

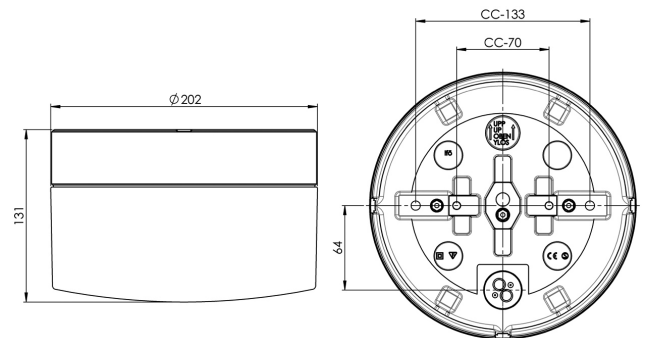

Luminaire specific information

Sensor function: Off/On: The light fitting is turned on by movement. Daylight control: The fitting can be set to remain turn down to the luminosity desired, e.g. daylight. Hold time: How long the fitting will remain lit after movement. Technical data: The microwave movement-sensor is adapted for indoor and outdoor use. Master/slave coupling: Max 1200W resistive or 400W inductive load. Installation height: Max 6 m. Max range: 4-10 m depending on installation, can be adjusted to 10/25/50/75/100 % of the max range. Hold time: 5s/30s/60s/300s/15 min/30 min, can be adjusted. Daylight control: 2-50 lux.

Maintenance

Disconnect the power to the luminaire. Unscrew the glass and clean it. Do not use detergents that contain solvents. Replace light source if necessary. Check the gasket and replace it if necessary. Screw the shade back on.

Spare parts

Shade Opus 200/135 matt opal, Article no.: 1-6183-30
Gasket silicone for thread 185,5 mm, Article no.: 03431

If the luminaire is modified the person responsible for the modification shall be considered manufacturer. Subject to errors in text. We reserve the right to change the technical specifications (without notice).