

Contrast Solhem LED DALI 3000K

Contrast is a series with different shades in matt opal glass. Each type of glass has received its own local name to honour the area. Ifö Contrast is suitable for both private and public settings.

EAN / GTIN	7312908043908
E-number	7508453
Article no.	8043-8001-10
Type designation	8262/DALI



Specification

Material	Porcelain
Base colour	White (NCS S 1000-N)
Glass	Matt opal glass
Glass thread (mm)	185,5 mm
Glass gasket	Silicone
Weight	2,44 kg
Diameter (mm)	290
Height (mm)	135
Lamp holder	LED
Light source	LED module, 12W **
Effect	12W
Lumen, light source	1350lm
Colour temperature	3000K
MacAdam	3 SDCM
Life span	L80/B10: 47 000 h
Ra	Min 90
Lighting control	DALI Type 2
Rated voltage	230V
Dimmable	DALI PHM126 min 3%
IP class	IP44
Insulation class	II
Energy class	E
D class	No
IK class	IK02
Ta	-30 - +25
Installation	Ceiling/wall
CC measurement (mm)	133, 70
Knock out opening	3
Cable inlet	Bottom inlet
Cable glands	Bottom inlet
Cable area, max	Max 5 x 2,5 mm ²
Bridging	Yes
Surface mounted cable	Yes
Connection	Terminal block
Family	Contrast
Design	Duoform

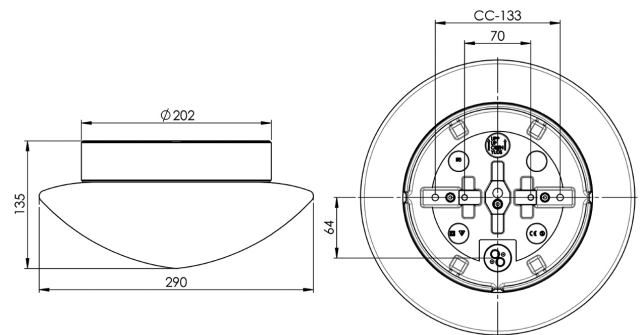

Maintenance

Disconnect the power to the luminaire. Unscrew the glass and clean it. Do not use detergents that contain solvents. Replace LED module if necessary. Check the gasket and replace it if necessary. Screw the shade back on.

Spare parts

Shade Solhem matt opal, Article no.: 1-6133
Gasket silicone for thread 185,5 mm, Article no.: 03431
LED module 12W DALI 3000K, Article no.: 1-54064-1930

** The device must under no circumstances be connected to the same phase as a magnetic ballast or other older fluorescent luminaires as these luminaires can generate overvoltage transients outside of EU regulatory standards when switched off or on. The luminaire can permanently damage or completely cease to function when connected.

If the luminaire is modified the person responsible for the modification shall be considered manufacturer. Subject to errors in text. We reserve the right to change the technical specifications (without notice).